

DALMAX-SG-242421-BEAST

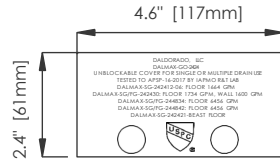

GRATE DETAIL

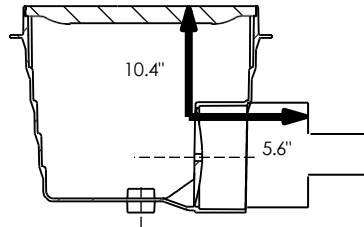
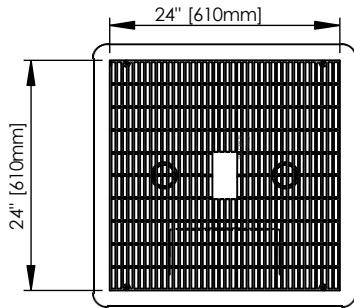
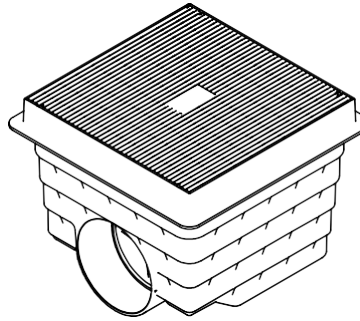

Minimum length before reduction > 16"

SUMP AND GRATE: UNBLOCKABLE SOFA CERTIFIED TO APSP/ANSI/ICC-16 2017, NSF/ANSI/CAN 50-2020, AND USPC. RPD FIELD CERTIFICATION IS NOT REQUIRED. CORROSION RESISTANT, NON-CONDUCTIVE, NON-MAGNETIC, AND REQUIRES NO BONDING.

SUMP: MOLDED FROM CERTIFIED HIGH-GRADE PVC WITH WATER STOP, 10-IN COUPLING, PREASSURE PLATE AND 2 - 2" BOTTOM FITTINGS FOR HYDROSTATIC RELIEF VALVES AS PART OF THE MOLDED PRODUCT. THE COUPLING CAN BE REDUCED TO EITHER 8-IN OR 6-IN BASED ON ENGINEERING CALCULATIONS. SEE MINIMUM LENGTH BEFORE REDUCTION CHART. THE MAXIMUM CERTIFIED FLOW MUST NOT BE EXCEEDED. MARKINGS REQUIRED BY LAW ARE IMPRINTED INSIDE THE SUMP REGARDING MANUFACTURER, MODEL NUMBER, SERVICE LIFE AND BORN ON DATE.

GRATE: ONE (1) FLAT 24-IN X 24-IN GRATE FORMED OF UV-STABILIZED MOLDED PVC, CERTIFIED TO APSP/ANSI/ICC-16 2017, NSF/ANSI/CAN 50-2020, AND USPC. THE TOP SURFACE OF THE GRATE HAS A TEXTURED DESIGN FOR SLIP RESISTANCE. GRATE SECTIONS ARE 0.20-IN (5MM) WIDE AND 1-IN (25.4MM) AVG. DEPTH FOR LOAD STRENGTH REQUIREMENTS. SPACE BETWEEN GRATE BARS DOES NOT EXCEED 0.39-IN (10MM). GRATE PROVIDES A MINIMUM 62% OPEN AREA FOR UNRESTRICTED WATER FLOW. THE MANUFACTURE DATE AND MARKING REQUIRED BY STANDARDS IS MOLDED INTO EACH GRATE.

INSTALLATION: FOLLOW DALDORADO SUPPLIED INSTALLATION INSTRUCTIONS AND WARNINGS. GRATE MUST BE INSTALLED WITHIN SUMP USING ONLY THE 316 SS 1/4"-20x1.25" MACHINE SCREWS (TESTED TO APSP/ANSI/ICC-16 2017) AS SUPPLIED BY DALDORADO. NO OTHERS ARE PERMITTED.

CERTIFIED MAXIMUM FLOW RATE:
FLOOR-1734 GPM WALL-1552 GPM

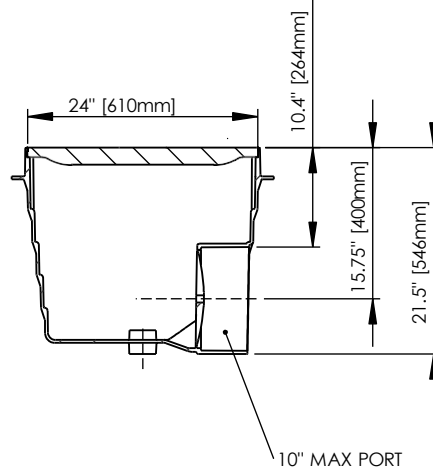
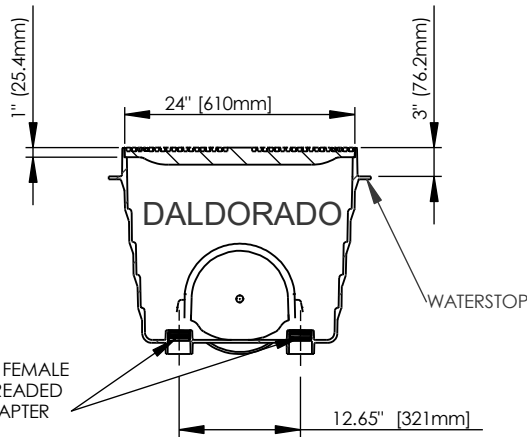

This DALMAX-SG-242421-BEAST Grate certified by IAPMO R&T against NSF/ANSI/CAN Standard 50 for Aquatic Facilities. For indoor and outdoor use. www.IAPMO.com

DaIMAX-SG-242421 OPTIONS	
TOTAL GPM	1734 FLOOR, 1552 WALL
PORT CONFIGURATIONS	ANY PER NOTES ABOVE
MAX PORT SIZE, SIDE	10-IN
MIN PORT SIZE, BUSH DOWN	6-IN
GRATE COLOR	WHITE

SUMP LIFE: LIFE OF THE AQUATIC FACILITY
GRATES AND FASTENERS: 25 YEAR SERVICE LIFE/10 YEAR WARRANTY

All drawing are saved in a *.dwg format and are provided as a service to our customers; dimensions supplied by Daldorado are for reference only. Daldorado or any authorized distributor of our products will not be held responsible from files which have been converted and does not warranty the documents against deficiencies or typographical errors of any kind. All measurements of the actual product must be verified before any custom fabrication in the field occurs. COPYRIGHT: This document is the property of Daldorado, LLC and is provided on an in-confidence basis, it may not be copied or reproduced without the permission of Daldorado or its authorized agent.

Product:	24x24x21 Sump & Grate Package	
Product #:	DaIMAX-SG-242421-BEAST	
Material:	PVC	Rev Date: 11/07/2024
Color:	WHITE	Rev By: DALDORADO

DALDORADO

4327 Arnold Ave, Naples, FL 34104
 Phone: 888.509.8128
www.daldorado.com