

ANTI WAVE POOL PRODUCTS

"ULTIMATE STORAGE REEL" Specifications Sheet

STORAGE REEL SPECIFICATIONS

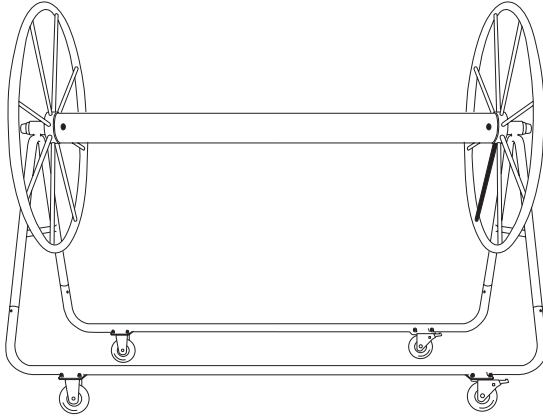

The **Ultimate Storeel** is a high-capacity storage unit for swimming racing lanes. It is of white powder coated, aluminum construction. The center spool's diameter is 6", designed specifically to minimize damage to the discs when removing lanes from the pool. The **Ultimate** is mounted on four 5" casters, two of which rotate and have brakes attached. Its capacity is seven 25m 4Runner or four 25m 6" lanes. A protective mesh cover is sold separately.

All Ultimate Storage Reel is supported by a 3-year warranty.

FRONT VIEW / PRINCIPAL DIMENSIONS

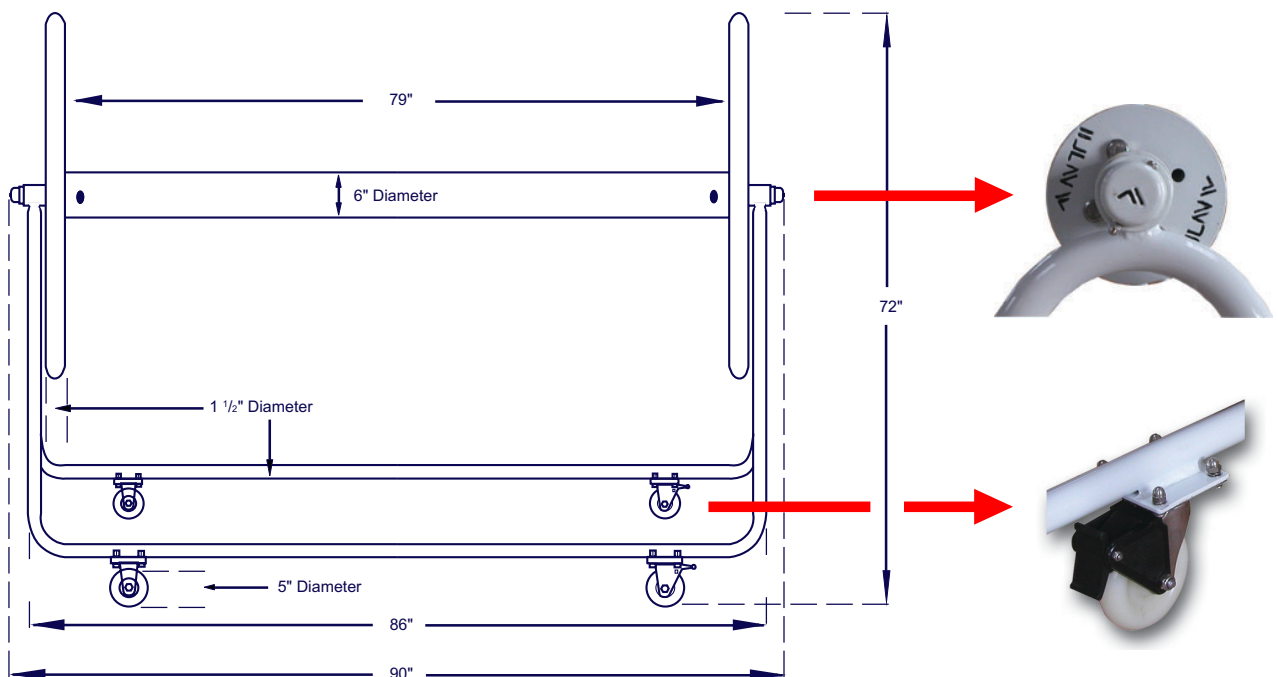

ANTI WAVE POOL PRODUCTS "Simply the Best"

1144 Northwest 53rd Street, Seattle, WA 98107

Tel: 206.676.8209 Fax: 206.784.9708 www.antiwave.com



ANTI WAVE POOL PRODUCTS

"ULTIMATE STORAGE REEL" Specifications Sheet

SIDE VIEW / PRINCIPAL DIMENSIONS

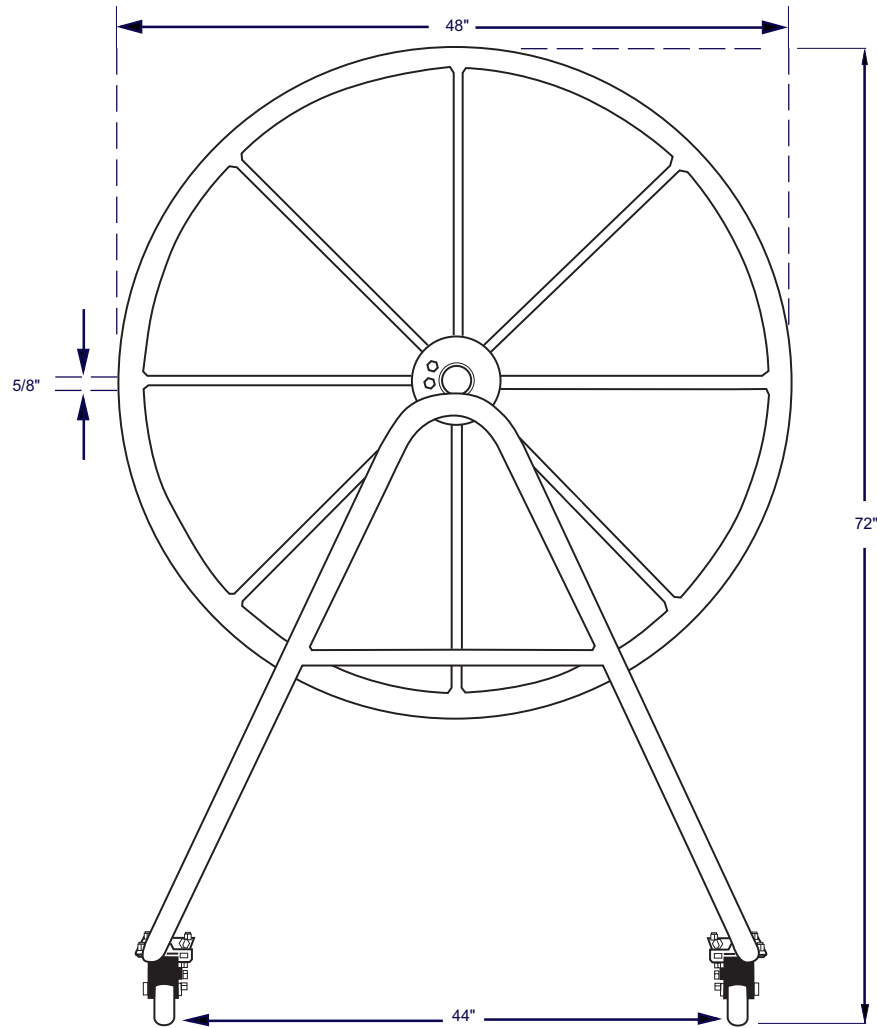

Ultimate offer a Storage large enough to hold a full set of lanes, which has unrivalled capacity. The SIX INCHES diameter center spool have SIX FEET SEVEN INCHES WIDE, designed to eliminated the possibility of damage to the discs.



SHIPPING SPECIFICATIONS

AW0615	"Ultimate" Storage Reel:	106#	(3 cartons, will ship by truck)
AW0691	"Ultimate" Storage Cover:	9#	(1 cartons, will ship by UPS)
AW0615 & AW0691	Shipped together:	113#	(3 cartons, will ship by truck)



ANTI WAVE POOL PRODUCTS *"Simply the Best"*

1144 Northwest 53rd Street, Seattle, WA 98107

Tel: 206.676.8209 Fax: 206.784.9708 www.antiwave.com

